

This article was downloaded by:

On: 23 January 2011

Access details: *Access Details: Free Access*

Publisher *Taylor & Francis*

Informa Ltd Registered in England and Wales Registered Number: 1072954 Registered office: Mortimer House, 37-41 Mortimer Street, London W1T 3JH, UK



## Journal of Coordination Chemistry

Publication details, including instructions for authors and subscription information:

<http://www.informaworld.com/smpp/title~content=t713455674>

### REACTIONS OF MOLYBDATES WITH POLYPHOSPHATES. 2. MAGNETIC RESONANCE STUDIES ON MOLYBDENUM(V) POLYPHOSPHATE AND ATP COMPLEXES

H. So<sup>a</sup>; M. Kolor<sup>a</sup>; P. R. Robinson<sup>a</sup>; G. P. Haight Jr.<sup>a</sup>; R. Linn Belford<sup>a</sup>

<sup>a</sup> School of Chemical Sciences, University of Illinois, Urbana, Illinois

**To cite this Article** So, H. , Kolor, M. , Robinson, P. R. , Haight Jr., G. P. and Belford, R. Linn(1979) 'REACTIONS OF MOLYBDATES WITH POLYPHOSPHATES. 2. MAGNETIC RESONANCE STUDIES ON MOLYBDENUM(V) POLYPHOSPHATE AND ATP COMPLEXES', *Journal of Coordination Chemistry*, 9: 1, 43 – 51

**To link to this Article:** DOI: 10.1080/00958977908073100

**URL:** <http://dx.doi.org/10.1080/00958977908073100>

PLEASE SCROLL DOWN FOR ARTICLE

Full terms and conditions of use: <http://www.informaworld.com/terms-and-conditions-of-access.pdf>

This article may be used for research, teaching and private study purposes. Any substantial or systematic reproduction, re-distribution, re-selling, loan or sub-licensing, systematic supply or distribution in any form to anyone is expressly forbidden.

The publisher does not give any warranty express or implied or make any representation that the contents will be complete or accurate or up to date. The accuracy of any instructions, formulae and drug doses should be independently verified with primary sources. The publisher shall not be liable for any loss, actions, claims, proceedings, demand or costs or damages whatsoever or howsoever caused arising directly or indirectly in connection with or arising out of the use of this material.

## REACTIONS OF MOLYBDATES WITH POLYPHOSPHATES. 2. MAGNETIC RESONANCE STUDIES ON MOLYBDENUM(V) POLYPHOSPHATE AND ATP COMPLEXES

H. SO, M. KOLOR, P. R. ROBINSON, G. P. HAIGHT, JR.,† and R. LINN BELFORD†

*School of Chemical Sciences, University of Illinois, Urbana, Illinois 61801*

*(Received July 25, 1978)*

Solutions containing  $(\text{NH}_4)_2\text{MoOCl}_5$  and pyrophosphate (PPi), tripolyphosphate (PPPi), or adenosine 5'-triphosphate (ATP) have been examined by EPR and  $^{31}\text{P}$  NMR. The intensities of the EPR signals accounted for 0.5–7% of the total molybdenum in each system. The five-line EPR spectrum for the Mo–PPi system was essentially the same as that observed before for the solution containing  $\text{Mo}_2\text{O}_4^{2+}$  and PPi. Only a one-line EPR spectrum was observed for the Mo–ATP system. Several different EPR spectra were observed for Mo–PPPi systems depending upon the Mo:PPPi ratio and the pH of the solution. These EPR spectra have been resolved by computer simulations and several EPR-active species have been identified. For solutions with Mo:PPPi < 1, the NMR spectra indicate an almost quantitative formation of  $\text{Mo}_2\text{O}_4(\text{P}_3\text{O}_{10})_2\text{H}_n^{n-8}$  above pH = 4. Solid  $\text{Na}_6[\text{Mo}_2\text{O}_4(\text{HP}_3\text{O}_{10})_2]\cdot 6\text{H}_2\text{O}$  was isolated by treating a solution with methanol. For solutions with Mo:PPPi > 1, the NMR spectra indicated formation of some other complexes in addition to the above one. For the Mo–PPi system, the NMR spectra show that one complex forms predominantly above pH = 5, but several different complexes form below pH = 5. Two broad peaks have been observed in NMR spectra of the Mo–ATP system and these are attributed to a  $\beta$ ,  $\gamma$ -coordinated ATP. Possible structures of some complexes are discussed.

### INTRODUCTION

Recently it has been found that hydrolysis of polyphosphates is enhanced dramatically in the presence of V(V) formed *in situ* by oxidation of  $\text{VO}^{2+}$  complexed by the polyphosphates.<sup>1–3</sup> This observation has prompted us to investigate interactions of another  $d^1$  species, Mo(V), with polyphosphates. In a previous paper,<sup>4</sup> we characterized this paramagnetic aqueous species  $\text{MoO}(\text{P}_2\text{O}_7)_2\text{H}_n^{n-5}$  by its EPR spectrum, which exhibits  $^{31}\text{P}$  superhyperfine lines. However, this paramagnetic species accounted for only 5% of the total molybdenum in the Mo–pyrophosphate system. Therefore, we have continued this investigation with  $^{31}\text{P}$  NMR studies designed to elucidate the structures of diamagnetic complexes that form between Mo and various polyphosphates including adenosine 5'-triphosphate (ATP) and adenosine 5'-diphosphate (ADP).

This paper reports  $^{31}\text{P}$  NMR spectra of molybdenum complexes of pyrophosphate (PPi), tripolyphosphate (PPPi) and ATP, and EPR spectra of the Mo–PPPi system.

### EXPERIMENTAL SECTION

$(\text{NH}_4)_2\text{MoOCl}_5$  was prepared according to the method of Saha and Banerjee.<sup>5</sup> All reagent grade chemicals –  $\text{Na}_4\text{P}_2\text{O}_7\cdot 10\text{H}_2\text{O}$ ,  $\text{Na}_5\text{P}_3\text{O}_{10}$ ,  $\text{Na}_2\text{HADP}\cdot 3\text{H}_2\text{O}$ , and  $\text{Na}_2\text{H}_2\text{ATP}\cdot 3\text{H}_2\text{O}$  – were used without further purification.  $(\text{NH}_4)_2\text{MoOCl}_5$  and a polyphosphate were dissolved in deionized water (normal or deuterated), purged with nitrogen, and brought to the desired pH with NaOH solution. The pH was measured with a Model LSX Sargent-Welch pH meter. For  $\text{D}_2\text{O}$  solutions, the apparent pH reading was increased by 0.40 to provide the pD value.<sup>6</sup> Direct meter readings are reported for solutions containing both  $\text{H}_2\text{O}$  and  $\text{D}_2\text{O}$ .

Phosphorus( $^{31}\text{P}$ ) NMR spectra were recorded on a Varian XL 100 spectrometer operating at 40.5 MHz in the pulsed mode. Transients were accumulated in and transformed by a Nicolet NIC-80 computer. The spectra were routinely proton-decoupled. Chemical shifts are referred to an external standard of 85%  $\text{H}_3\text{PO}_4$  with chemical shifts increasing with increasing field, as is customary in  $^{31}\text{P}$  NMR. The EPR

spectra were recorded on a Varian E-9 spectrometer operating at 9.5 GHz and 100 kHz modulation. The microwave frequency was measured with a Hewlett-Packard 5240-A frequency meter and DPPH was used to check the magnetic field.

An attempt was made to isolate a pure Mo-PPPi complex by treating a 0.5 *F* solution at pH = 5 with methanol at 0°C. The resulting brown oil was repeatedly treated with methanol to produce a burnt-orange powder. The solid was recrystallized three times from water and methanol, washed with ether, and vacuum-dried. Calculated for Na<sub>6</sub>[Mo<sub>2</sub>O<sub>4</sub>(HP<sub>3</sub>O<sub>10</sub>)<sub>2</sub>]·6H<sub>2</sub>O: Na, 13.66; Mo, 19.00; H, 1.39; P, 18.40. Found: Na, 13.4; Mo, 19.07; H, 1.27; P, 18.32. (Elemental analyses were performed by the Microanalytical Laboratory of the University of Illinois, Urbana-Champaign.)

## RESULTS

### Mo-Tripolyphosphate System

When (NH<sub>4</sub>)<sub>2</sub>MoOCl<sub>5</sub> was dissolved in an aqueous solution of Na<sub>5</sub>P<sub>3</sub>O<sub>10</sub>, several different EPR spectra were observed, depending upon the Mo-PPPi ratio and the pH of the solution. The strongest signal appeared for solutions with Mo:PPPi < 1 at pH ~ 4. Using an ethanolic solution of (NH<sub>4</sub>)<sub>2</sub>MoOCl<sub>5</sub> as a

standard, we estimate the relative amount of the EPR-active species to be about 7% of the total molybdenum five minutes after preparation. The spectrum, which decays gradually without any change in its general feature, consists of a strong central line due to Mo isotopes with nuclear spin *I* = 0 (abundance, 75%) and weak hyperfine lines due to isotopes with *I* = 5/2 (25%) with several lines superimposed on each. The central line is shown in Figure 1. The low-field side of the spectrum is very similar to that of the five-line spectrum<sup>4</sup> of MoO(P<sub>2</sub>O<sub>7</sub>)<sub>2</sub>·H<sub>n</sub><sup>n-5</sup>. When a five-line spectrum was subtracted from the observed one, a three-line spectrum remained.

Thus we have tried to simulate the central line assuming that only two molybdenum complexes — one with four effectively equivalent phosphates and another with two effectively equivalent phosphates — contribute to the spectrum and neglecting the contribution of Mo isotopes with *I* = 5/2 to the central line. The solution spectrum of each complex can be described by a spin Hamiltonian:

$$\mathcal{H} = g\beta BS_z + \text{hap} \sum_{p=1}^n I_p \cdot S$$

where *g* and *a<sub>p</sub>* are the isotropic *g* value and the superhyperfine coupling constant due to <sup>31</sup>P (*I* = 1/2), respectively. The simulated spectrum shown in Figure

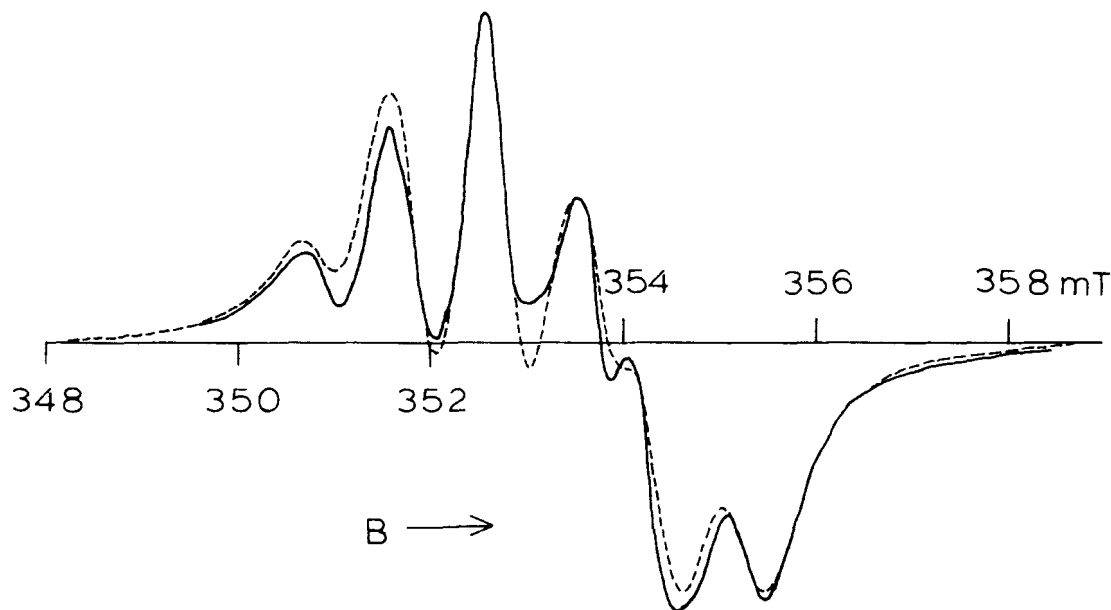

FIGURE 1 EPR spectrum of Mo-PPPi complexes. ——— Observed spectrum at room temperature, [(NH<sub>4</sub>)<sub>2</sub>MoOCl<sub>5</sub>] = 0.05 M, [Na<sub>5</sub>P<sub>3</sub>O<sub>10</sub>] = 0.10 M, and pH = 4.5. Microwave frequency 9.5062 GHz, scan range 200 G, time constant 1.0 sec, modulation amplitude 1 G, receiver gain 1.25 × 10<sup>-3</sup>, scan time 8 min. - - - - - Simulated spectrum. See the text for details.

1 was obtained with the parameters listed below:

Complex 1 ( $n = 4$ )  $g = 1.9253$ ;  $a_p = 25.8$  Hz;  
 $W = 13.2$  MHz;  $r = 1.0$

Complex 2 ( $n = 2$ )  $g = 1.9172$ ;  $a_p = 24.0$  MHz;  
 $W = 15.9$  MHz;  $r = 1.0$

Here  $W$  is the half-width at half height of each superhyperfine absorption line, the shape of which is assumed to be Lorentzian, and  $r$  represents the relative amount of each complex.

A quite different spectrum is characteristic of solutions with  $\text{Mo:PPPi} = 2$ . At  $\text{pH} = 3.8$ , a spectrum (Figure 2A) appears immediately after preparation and decays gradually. The relative amount of the EPR-active species was about 0.7% of the total

molybdenum five minutes after preparation. At  $\text{pH} = 3.0$ , the same spectrum was observed, but its intensity increased gradually for 30 minutes after preparation and then the spectral shape changed to the one shown in Figure 2B. The maximum amount of the EPR-active species was about 0.5% of the total molybdenum. When a three-line spectrum with a superhyperfine coupling constant similar to that of Complex 2 was subtracted from either of these spectra, one broad featureless spectrum remained. By mixing these two component spectra in different ratios, we could simulate both spectra as shown in Figures 2A and 2B. Although the broad one-line spectrum may be simulated in various ways, we assumed that this spectrum comes from another 1:1

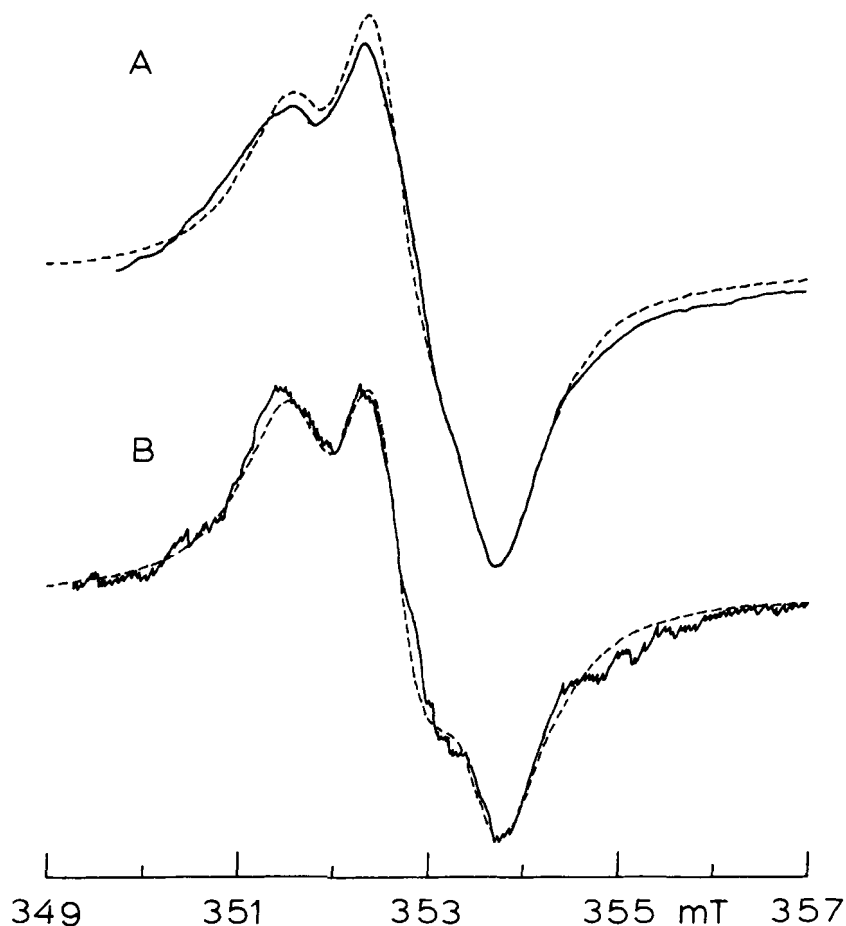

FIGURE 2 EPR spectra of Mo-PPPi complexes. ———— Observed spectra at room temperature,  $[(\text{NH}_4)_2\text{MoOCl}_5] = 0.02$  M, and  $[\text{Na}_5\text{P}_3\text{O}_{10}] = 0.01$  M. Microwave frequency 9.5007 GHz, scan range 200 G, time constant 1.0 sec, modulation amplitude 2 G, scan time 4 min. - - - - - Simulated spectra. See the text for details. (A)  $\text{pH} = 3.8$ , receiver gain  $6.3 \times 10^3$ , 5 min after preparation. (B)  $\text{pH} = 3.0$ , receiver gain  $1.25 \times 10^4$ , 70 min after preparation.

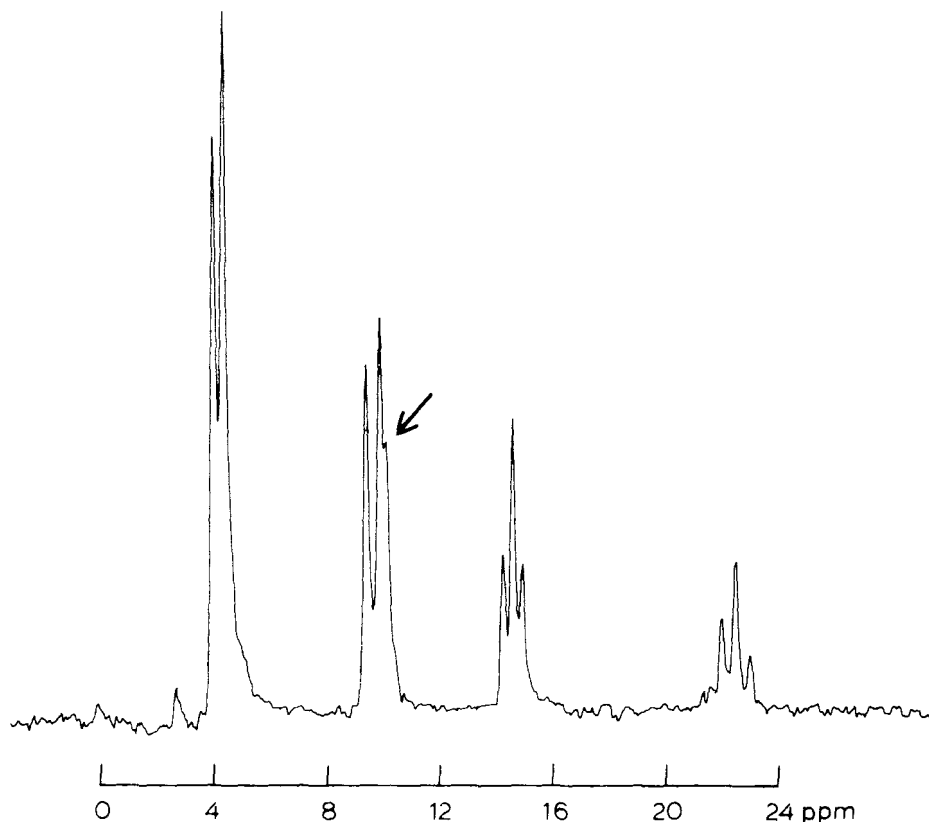

FIGURE 3 The 40.5 MHz  $^{31}\text{P}$  NMR spectrum of a solution containing Mo:PPPi = 0.6 at pD = 5.8. From left to right the groups of peaks represent the terminal P atoms in the coordinated PPPi, the terminal P atoms in free PPPi, the middle P atom in the coordinated PPPi, and the middle P atom in free PPPi. The small peak indicated by an arrow comes from PPI produced by hydrolysis of PPPi.

Mo-PPPi complex with a linewidth similar to that of three-line spectrum. The parameters used in simulating the spectra are as follows:

Complex 3 ( $n = 2$ )  $g = 1.9248$ ;  $a_p = 23.3$  MHz;  
 $W = 18.2$  MHz

Complex 4 ( $n = 2$ )  $g = 1.9255$ ;  $a_p = 11.0$  MHz;  
 $W = 17.1$  MHz

The ratio Complex 4:Complex 3 was 0.60 for Figure 2A and 0.22 for Figure 2B, respectively.

A typical  $^{31}\text{P}$  NMR spectrum for solutions containing Mo:PPPi  $< 1$  is shown in Figure 3. There are two sets of peaks, each consisting of one doublet and one triplet. One set is the same as the spectrum of free PPPi, the doublet and the triplet corresponding to the terminal and the middle phosphorus atoms, respectively.<sup>7</sup> The other set, which is shifted downfield, has a smaller spin-spin coupling constant than the noncoordinated one. Since a similar downfield shift and a decrease in the coupling constant were

observed for the PPPi ion coordinated to Co(III),<sup>8</sup> this set is attributed to the PPPi coordinated to Mo(V). Chemical shifts and coupling constants for this complex at several different pH's are summarized in Table I.

In order to determine the stoichiometry of the complex in solution, we recorded NMR spectra for solutions containing Mo and PPPi in different ratios. The ratios of the coordinated and non-coordinated PPPi's measured from the integrated NMR peak intensities indicated an almost quantitative formation of 1:1 Mo-PPPi complex for pD = 4.2–7.3. Thus the peaks corresponding to the free PPPi almost disappeared for solutions with Mo:PPPi = 1. However, at pD = 2.4, the 1:1 complexation was not complete.

A  $^{31}\text{P}$  NMR spectrum for a solution containing Mo:PPPi = 1.5 showed several new peaks in addition to those that can be ascribed to the 1:1 complex; see Figure 4.

TABLE I  
 $^{31}\text{P}$  NMR spectral data of molybdenum polyphosphates

Complex	pD <sup>a</sup>	Chem. shift (ppm) <sup>b</sup>	Multiplicity <sup>c</sup>	Coupling const. (Hz)	Coordination chem. shift <sup>d</sup>
$\text{Mo}_2\text{O}_4(\text{P}_2\text{O}_7)\text{H}_n^{n-5}$	6.0	3.0	s		-5.3
$\text{Mo}_2\text{O}_4(\text{P}_3\text{O}_{10})\text{H}_n^{n-8}$	2.4	8.6	d	13.1	-2.7
		19.1	t	13.2	-4.3
	4.2	5.8	d	14 <sup>e</sup>	-5.2
		16.3	t	14 <sup>e</sup>	-7.2
	5.8	4.2	d	14.1	-5.5
		14.6	t	14.1	-7.9
	7.3	4.0	d	14.5	-2.0
Mo-ATP		14.5	t	14.4	-6.8
	3.3	7.2			-3
		18.3			-5
	5.1	5			-6
		18.1			-5

<sup>a</sup>Meter reading +0.4 except for the first one, which is a direct meter reading for a solution containing 50%  $\text{D}_2\text{O}$ .

<sup>b</sup>Relative to 85%  $\text{H}_3\text{PO}_4$ .

<sup>c</sup>s = singlet, d = doublet, t = triplet.

<sup>d</sup>ppm from the corresponding phosphorus resonance in free polyphosphate.

<sup>e</sup>Average of the two values from the doublet and the triplet which were different by 1 Hz.

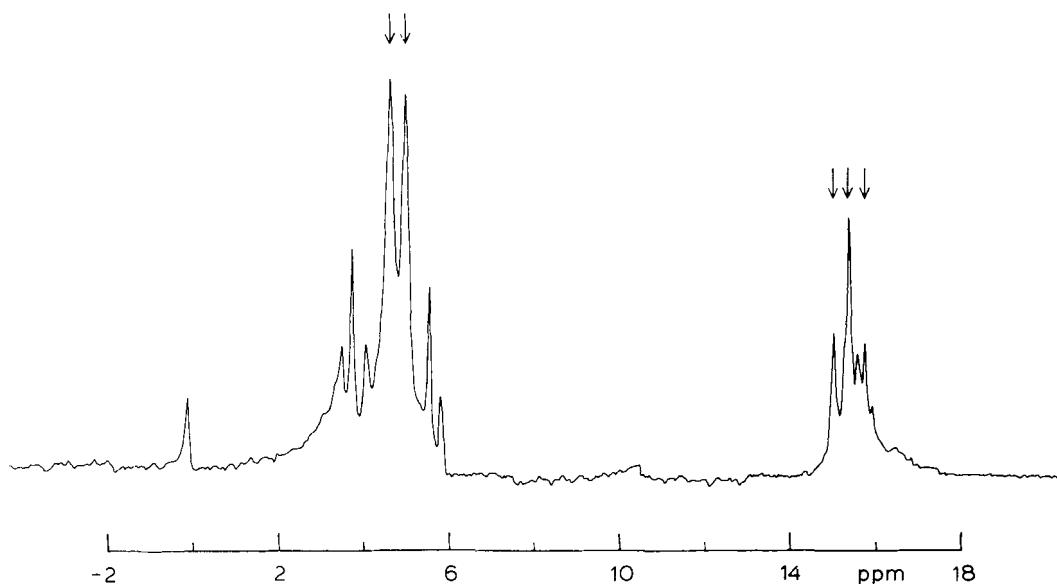

FIGURE 4 The 40.5 MHz  $^{31}\text{P}$  NMR spectrum of a solution containing Mo:PPPi = 1.5. A doublet and a triplet which come from the 2:2 complex are pointed out by arrows.

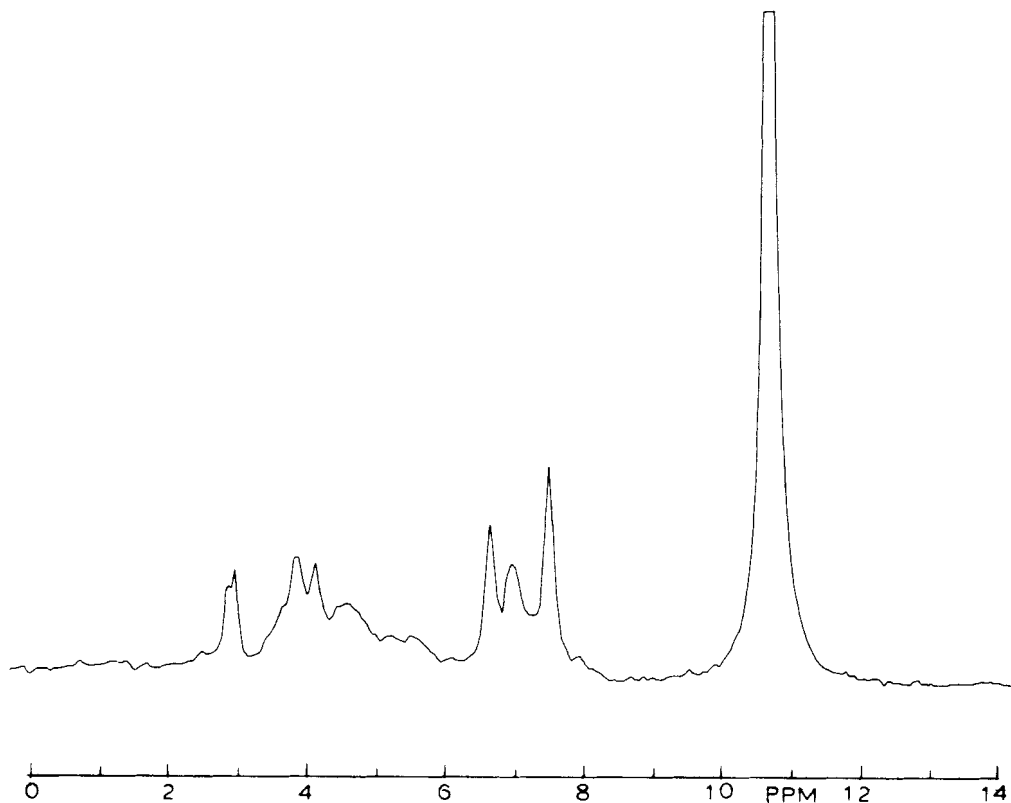

FIGURE 5 The 40.5 MHz  $^{31}\text{P}$  NMR spectrum of a solution containing Mo:PPi = 1.0 at pH = 4.3. The peak at 10.5 ppm comes from free PPi.

### *Mo-Pyrophosphate System*

The five-line EPR spectrum ( $g = 1.926$ ,  $\Delta\nu = 26$  MHz) for the solution containing  $(\text{NH}_4)_2\text{MoOCl}_5$  and  $\text{Na}_4\text{P}_2\text{O}_7$  was essentially the same as that reported before<sup>4</sup> for the solution containing  $\text{Mo}_2\text{O}_4^{2+}$  and  $\text{P}_2\text{O}_7^{4-}$ . Unlike the Mo-PPi system, no three-line spectrum was observed even for solutions with Mo:PPi = 2.

The  $^{31}\text{P}$  NMR spectra for solutions containing Mo:PPi < 1 at pH  $\sim 6$  show two peaks, one of which corresponds to free PPi.<sup>7</sup> The other peak which occurs at a lower field is attributed to the coordinated PPi. If a 2:2 Mo-PPi complex is assumed to form,<sup>4</sup> only partial complexation occurs. For a solution containing Mo:PPi = 1 at pH = 6, the peak corresponding to free PPi still accounted for 25% of the total PPi. For solutions below pH = 5, many additional peaks have been observed. See Figure 5.

### *Mo-ATP and Mo-ADP Systems*

For a solution with Mo:ATP = 1 at pH = 2.0, a featureless EPR signal ( $g = 1.924$ ) was observed. The intensity of the signal, which accounted for about 0.7% of the total molybdenum three minutes after preparation, decreased rapidly.

Phosphorus( $^{31}\text{P}$ ) NMR spectra were measured for solutions containing  $(\text{NH}_4)_2\text{MoOCl}_5$  and  $\text{Na}_2\text{H}_2\text{ATP}$  or  $\text{Na}_2\text{HADP}$  at various pH's. Only the spectra for Mo-ATP mixtures below pH = 6 showed clear evidence of complex formation. The spectrum for the 1:1 Mo-ATP mixture at pH = 5.1 is shown in Figure 6. The sharp peaks correspond to free ATP,<sup>9</sup> and the two broad peaks are attributed to the Mo-ATP complex. Downfield coordination chemical shifts have previously been observed<sup>8,10</sup> upon coordination of ATP to Co(III) and  $\text{UO}_2^{2+}$ . Thus the peak at 18 ppm can be assigned to  $\text{P}_\beta$  of

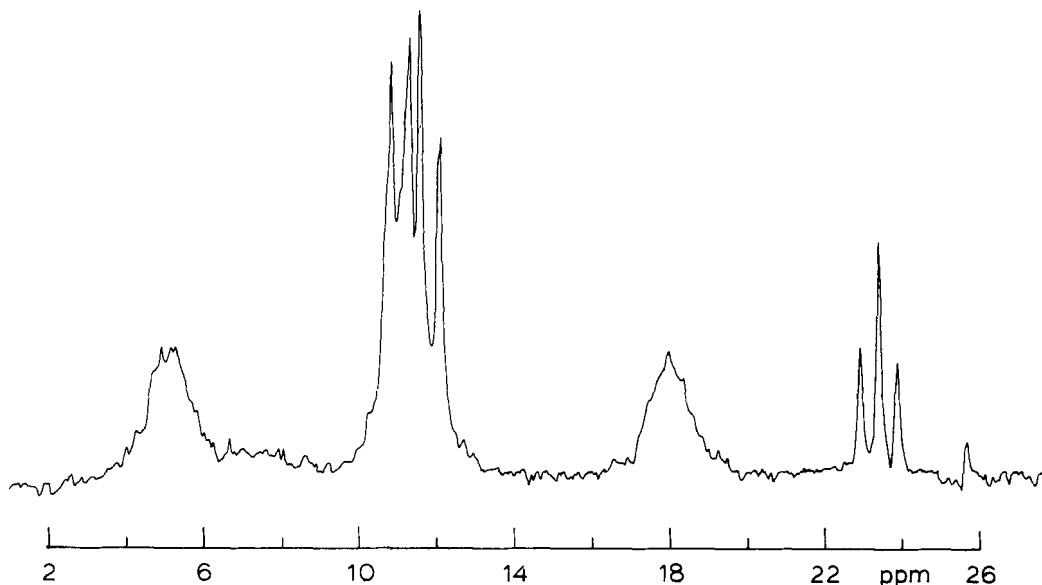

FIGURE 6 The 40.5 MHz  $^{31}\text{P}$  NMR spectrum of a solution containing Mo:ATP = 1.0 at pD = 5.1. Sharp peaks represent free ATP and broad peaks represent coordinated ATP.

the coordinated ATP. The peak at 5 ppm may be assigned to either  $P\alpha$  or  $P\gamma$ , but not to both, since its intensity is similar to that of the peak at 18 ppm.

## DISCUSSION

### Mo-Tripolyphosphate System

In our earlier work,<sup>4</sup> no EPR spectrum could be observed for the solution prepared by mixing solutions of  $\text{Mo}_2\text{O}_4^{2+}$  and  $\text{Na}_5\text{P}_3\text{O}_{10}$ . However, when a monomeric molybdenum compound,  $(\text{NH}_4)_2\text{MoOCl}_5$ , was dissolved in a solution of  $\text{Na}_5\text{P}_3\text{O}_{10}$ , several EPR-active species could be detected. No EPR signal could be observed for an aqueous solution of  $(\text{NH}_4)_2\text{MoOCl}_5$  without any polyphosphate species at pH  $\sim 4$ . This is consistent with rapid hydrolysis<sup>5</sup> of  $\text{MoOCl}_5^{2-}$  and complete dimerization<sup>11</sup> of  $\text{MoO}^{3+}$  to  $\text{Mo}_2\text{O}_4^{2+}$ . Thus all EPR signals are attributed to Mo-tripolyphosphate complexes. The small  $g$  values of all these complexes, similar to  $g = 1.926$  for  $\text{PMoW}_{11}\text{O}_{40}^{4-}$ , where Mo is surrounded by six oxygen atoms,<sup>12</sup> suggest that no chlorine is coordinated to Mo.<sup>13</sup>

Complex 1 may be formulated as  $\text{MoO}(\text{P}_3\text{O}_{10})_2 \cdot \text{H}_n^{n-7}$ , and Complexes 2, 3, and 4 as  $\text{MoO}(\text{H}_2\text{O})_2 \cdot (\text{P}_3\text{O}_{10})\text{H}_n^{n-2}$ . It seems that 1:1 Mo-PPPi complexes are stabilized by the tridentate chelation, while no 1:1 monomeric Mo-PPi complex is formed.

There are several different ways in which a PPPi ion can coordinate to a Mo=O group. For example, two *cis* equatorial sites may be occupied by two terminal phosphates or by one terminal and the middle phosphates. Two terminal phosphates can also coordinate to two *trans* sites. Although it is not possible to infer the mode of coordination directly from the EPR data, the conformation of the PPPi for a given mode of coordination can be determined on the basis of the phosphorus superhyperfine coupling constant,  $a_p$ . The  $a_p$  value is determined mainly by the location of the phosphorus atom with respect to the  $4d_{xy}$  orbital of the molybdenum atom bearing the unpaired electron. For the complex oxo-2-sulfidophenolatodi-isopropylidithiophosphinato-molybdenum (V),<sup>16</sup> where the  $d_{xy}$  orbital is pointed directly towards the phosphorus atom,  $a_p$  is 105 MHz. The  $a_p$  values for Complexes 1–3, 23.3–25.8 MHz, are much smaller than this and are similar to that<sup>4</sup> of  $\text{MoO}(\text{P}_2\text{O}_7)_2\text{H}_n^{n-5}$ . The conformation of pyrophosphate in  $\text{MoO}(\text{P}_2\text{O}_7)_2\text{H}_n^{n-5}$  is probably the same as that<sup>17</sup> found in  $\text{Na}_6\text{Cu}(\text{P}_2\text{O}_7)_2 \cdot 16\text{H}_2\text{O}$ . Here the copper ion is at a center of symmetry and is chelated by two PPI ions to give four close oxygen neighbors in a nearly square planar configuration. One phosphorus atom is above the plane containing the  $\text{CuO}_4$  group and the other phosphorus atom of the same PPI ion is below the plane. In this conformation all phosphorous atoms are in equivalent locations



with respect to the  $d_{xy}$  orbital and the superhyperfine interaction is maximized. For each mode of coordination of a PPPi ion to a Mo=O group, the PPPi can have either a conformation which allows the phosphorus atoms to have this large superhyperfine interaction or conformations which allow smaller superhyperfine interactions. Complexes 1–3 correspond to the former and Complex 4 to the latter. We can also eliminate the *trans* coordination for the 1:2 Mo–PPPi complex, for it cannot produce a conformation which allows four phosphorus atoms to have the large superhyperfine interaction.

For solutions containing Mo:PPPi < 1, the NMR data show that the predominant species formed is a 1:1 Mo–PPPi complex, in which the two terminal phosphates are effectively equivalent. Since molybdenum exists as  $\text{Mo}_2\text{O}_4^{2+}$  in the range  $\text{pH} = 1\text{--}10^{11}$ , the complex may be formulated as  $\text{Mo}_2\text{O}_4(\text{P}_3\text{O}_{10})_2\text{H}_n^{n-8}$ . The analysis of the solid precipitated at  $\text{pH} = 5$  showed that  $n$  is 2, but species with different  $n$  values are expected to coexist in solution. Two different structures, (A) and (B), can be envisaged for the complex. The middle phosphate group is coordinated to the axial site of the Mo=O group in (A) and to an equatorial site in (B). Although

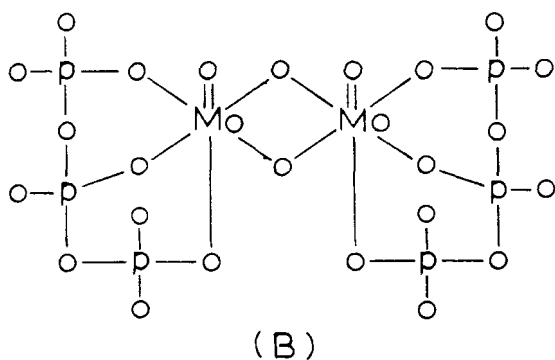
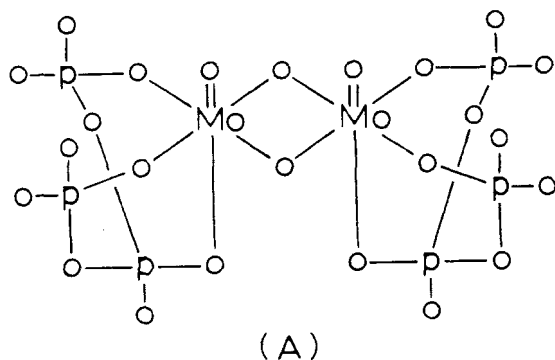

conformations with two equivalent terminal phosphates are possible only for Structure (A), the possibility that the two inequivalent terminal phosphates in Structure (B) have the same chemical shift and spin-spin coupling constant cannot be ruled out absolutely.

The fact that two discrete spectra are observed for the free and the coordinated PPPi's shows that the complex is substitution-inert on the NMR time scale. From the minimum-frequency separation between the free and the coordinated PPPi peaks, the mean lifetime can be estimated to be longer than  $10^{-2}$  sec. This complex has also been found to be much more resistant to air oxidation than the Mo–PPi complex. These observations are all consistent with the proposed structures where all available coordination sites are occupied by oxygen atoms of two PPPi ions. The greater extent of complexation for Mo–PPPi as compared to that for Mo–PPi is another indication of stabilization by tridentate chelation. However, at low pH protonation competes with complex formation, reducing the extent of complexation even for Mo–PPPi.

The chemical shifts of the coordinated PPPi are pH dependent and the spectrum appears to be that of a single complex in regions of pH where more than one protonated species can exist. These phenomena are attributed to rapid exchange of protons between the coordinated PPPi and the solvent water molecules.<sup>7</sup>

The changes in chemical shifts upon coordination of phosphates to metal ions have been described for several systems.<sup>8,9,14</sup> For example, Cornelius *et al.*<sup>8</sup> observed coordination chemical shifts of  $-9.1$  and  $-13.9$  ppm for the terminal and middle phosphorus atoms in  $[\text{Co}(\text{NH}_3)_3\text{P}_3\text{O}_{10}]^{2-}$ , which are about twice as large as the corresponding maximum coordination shifts,  $-5.5$  and  $-7.9$  ppm, for the Mo–PPPi complex. The downfield coordination chemical shifts may be attributed to electron-withdrawing effects of the metal ions. The difference between shifts for the cobalt and molybdenum complexes may be due to the very strong electron donation by the oxo-oxygen coordinated to Mo compared to the ammonia molecules coordinated to Co.

The spin-spin coupling constant  $J$  is also sensitive to the environment of the PPPi ion. In general, it decreases as the extent of association of the PPPi ion with any cation increases.<sup>14</sup> The  $J$  values for the free PPPi are  $16.7\text{--}19.4$  Hz,<sup>7</sup> while our values for the Mo–PPPi complex are  $13.1\text{--}14.5$  Hz.

### Mo-Pyrophosphate System

EPR and UV spectra for this system were studied before and the structures of two complexes, one monomeric and one dimeric, were proposed.<sup>4</sup> The single peak at 3 ppm observed for solutions at pH ~ 6 may be ascribed to the proposed 2:2 Mo-PPi complex where all four phosphate groups are equivalent. But our NMR spectra (see Figure 5 and Results section) clearly show that at pH < 5 there are several different diamagnetic complexes, the structures of which have not been established.

### Mo-ATP System

Adenosine triphosphate, ATP, is known to form mainly  $\alpha$ ,  $\beta$ ,  $\gamma$ - or  $\beta$ ,  $\gamma$ -coordinated metal complexes, although some  $\alpha$ ,  $\beta$ -coordinated complexes have been postulated as the active complexes for the hydrolysis of ATP.<sup>15</sup> Thus the peak at 5 ppm quite probably corresponds to the P $_{\gamma}$  atom of the coordinated ATP. Here again there are several possible modes of coordination, depending upon which available sites (one axial and two equatorial sites per molybdenum atom) the  $\beta$  and  $\gamma$  phosphate coordinate to. And for each mode of coordination there can be two diastereomers which are characterized by different absolute configurations about the  $\beta$  phosphorus atom.<sup>8</sup> The broad, unresolved peaks in Figure 6 indicate that the system contains more than one of these isomers. Since the  $\beta$ ,  $\gamma$ -coordination with other metal ions may be accompanied by some kind of interaction between the adenine ring and the metal ion,<sup>18</sup> we have searched for evidence of such interaction with Mo by proton NMR measurements. These measurements so far have provided no definite evidence for any interaction.

### CONCLUDING REMARKS

A variety of Mo-polyphosphate complexes has been observed in this work and structural information has been obtained for some species. Further work is needed to establish the relations among these species, i.e., which species are in equilibrium, which species is converted to which before the equilibrium is reached, etc. Another interesting problem is to identify the species responsible for the metal-ion-catalyzed hydrolysis of polyphosphates. In contrast to the vanadium-polyphosphate systems,<sup>1-3</sup> our preliminary studies have not shown *in situ* bromate oxidation of Mo(III) to Mo(V) or Mo(V) to Mo(VI) to increase the

hydrolysis rate significantly. Molybdenum(V) so far appears to be no more effective than divalent metal ions such as Cu<sup>2+</sup> in enhancing the hydrolysis rate of polyphosphates. Still, in view of considerable current interest in the mechanism of metal-ion-promoted dephosphorylation,<sup>15</sup> it will be worthwhile to carry out detailed studies on the mechanism of hydrolysis for these systems which are amenable to both EPR and <sup>31</sup>P NMR techniques.

### ACKNOWLEDGEMENT

This research was supported by the National Institutes of Health under Grant No. GM-22887, and by the National Science Foundation Quantum Chemistry Program. We thank Mr. Mark J. Nilges for the use of his computer program in simulating the EPR spectra. H.S. thanks Sogang University, Seoul, Korea, for financial assistance during a sabbatical leave.

### REFERENCES

1. G. M. Woltermann, R. A. Scott and G. P. Haight, Jr., *J. Amer. Chem. Soc.*, **96**, 7569 (1974).
2. G. P. Haight, Jr., R. A. Scott and G. M. Woltermann, *Physiol. Chem. & Physics*, **6**, 375 (1974).
3. G. M. Woltermann, R. L. Belford and G. P. Haight, Jr., *Inorg. Chem.*, **16**, 2985 (1977).
4. T. Imamura, G. P. Haight, Jr. and R. L. Belford, *Inorg. Chem.*, **15**, 1074 (1976).
5. H. K. Saha and A. K. Banerjee, *Inorganic Syntheses*, **15**, 100 (1974).
6. P. K. Glasoe and F. A. Long, *J. Phys. Chem.*, **64**, 188 (1960).
7. M. M. Brutchfield, C. F. Callis, R. R. Irani and G. C. Roth, *Inorg. Chem.*, **1**, 813 (1962).
8. R. D. Cornelius, P. A. Hart and W. W. Cleland, *Inorg. Chem.*, **16**, 2799 (1977).
9. M. Cohn and T. R. Hughes, Jr., *J. Biol. Chem.*, **235**, 3250 (1960).
10. K. E. Rich, R. T. Agarwal and I. Feldman, *J. Amer. Chem. Soc.*, **92**, 6818 (1970).
11. C. R. Hare, I. Bernal and H. B. Gray, *Inorg. Chem.*, **1**, 831 (1962).
12. J. J. Altenau, M. T. Pope, R. A. Prados and H. So, *Inorg. Chem.*, **14**, 417 (1975).
13. See, for example, E. I. Stiefel, *Progress in Inorganic Chemistry*, **22**, 1 (1977) for a list of EPR parameters for various molybdenum complexes.
14. M. M. Brutchfield and R. R. Irani, *J. Amer. Chem. Soc.*, **87**, 2815 (1965).
15. H. Siegel and P. E. Amsler, *J. Amer. Chem. Soc.*, **98**, 7390 (1976).
16. E. I. Stiefel, W. E. Newton and N. Pariyadath, *J. Less-Common Met.*, **54**, 513 (1977).
17. P. Yuen and R. L. Collin, *Acta Cryst.*, **B30**, 2513 (1974).
18. J. Granot and D. Fiat, *J. Am. Chem. Soc.*, **99**, 70 (1977).